

ITEM	QTY	DESCRIPTION	LENGTH	UM	PART NUMBER	MATERIAL	TYP	
1	2	WASHER, CAM FOLLOWER		EA	319003010		D	
2	1	BEARING, CAM FOLLOWER TIRE		EA	3120-2A-P7		D	
3	1	TIRE, CAM FOLLOWER		EA	330050370		D	
4	1	RACE, CAM FOLLOWER TIRE		EA	3120-2A-P8		D	
5	1	BOLT, HOLD DOWN		EA	312012640		D	
6	1	NUT, JAM 5/8"-18 GRADE 5		EA	*94846A535	STEEL	P	
7	1	PIN, CAM FOLLOWER TIRE		EA	312012610		D	
8	1	FITTING, GREASE STRAIGHT 1/4"-28		EA	*1095K41	STEEL	P	
9	1	PIN, CAM FOLLOWER PIVOT		EA	312012620		D	
10	2	SPACER, BEARING		EA	312012660		D	
11	2	SEAL, CAM FOLLOWER BEARING		EA	3120-2A-P9		D	
12	2	SLEEVE, SEAL RETAINING		EA	312012650		D	
13	1	BEARING, CAM FOLLOWER		EA	3120-2A-P11		D	
14	1	ARM, CAM FOLLOWER		EA	312012710		D	
15	1	FITTING, GREASE STRAIGHT 1/4"-28		EA	*1095K41	STEEL	P	
		* PURCHASE FROM McMASTER-CARR						

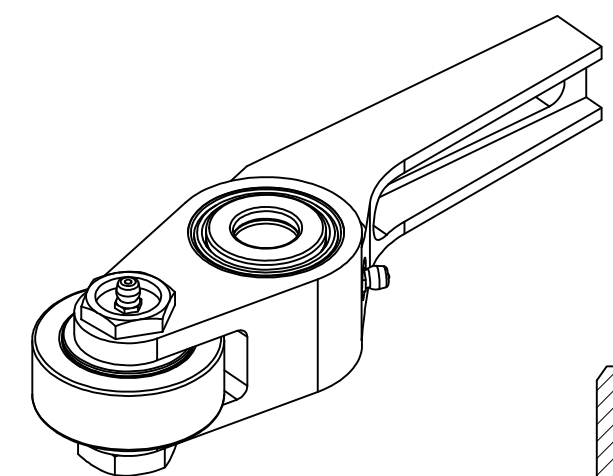

ISOMETRIC ASSMBLED VIEW
(FOR REFERENCE ONLY)

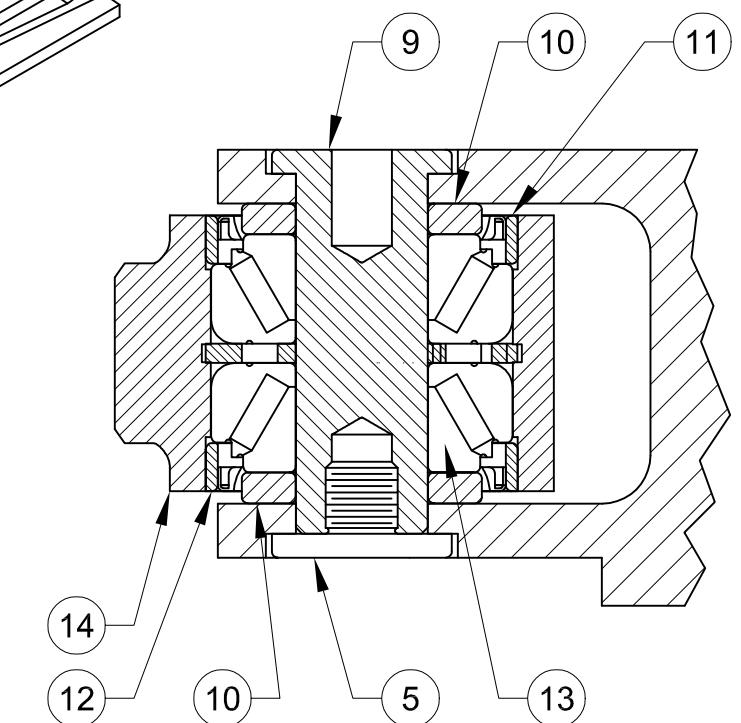

SECTION THRU
BEARING ASSEMBLY

- A** THE CAM FOLLOWER TIRE IS OFFERED AS A COMPLETE ASSEMBLY UNDER REG-ELLEN PART NUMBER: 330050370A
- B** ASSEMBLE USING REMOVEABLE THREAD LOCKING COMPOUND



THIS DRAWING IS THE PROPERTY OF REG-ELLEN MACHINE TOOL. IT SHALL NOT BE COPIED (IN WHOLE OR IN PART), FOR MANUFACTURE OR OTHERWISE DISCLOSED WITHOUT PRIOR WRITTEN CONSENT.

TOLERANCES		SCALE: 1:1
MACHINING	FABRICATION	DRAWN BY: MLGATES
X. ± .040	ALL ± .06	DATE: 06JAN20
X.X ± .020	ANGULAR 2°	CHECKED BY:
X.XX ± .010	ALL FINISHES 125mu	DATE:
X.XXX ± .005	DEBURR ALL SHARP CORNERS OR EDGES	
ANGULAR ± 1/2°		

TITLE: HARTFORD, 10-300/20-225 THD ASSEMBLY, CAM FOLLOWER		
SIZE: B	SHEET: 1 OF 1	REV: B
DWG NO: 312012710A		

AUTOCAD DRAWING: FORM REVISION 13MAR12